

Lunar Reconnaissance Orbiter Mission Status

James Rice
NASA Goddard Space Flight Center

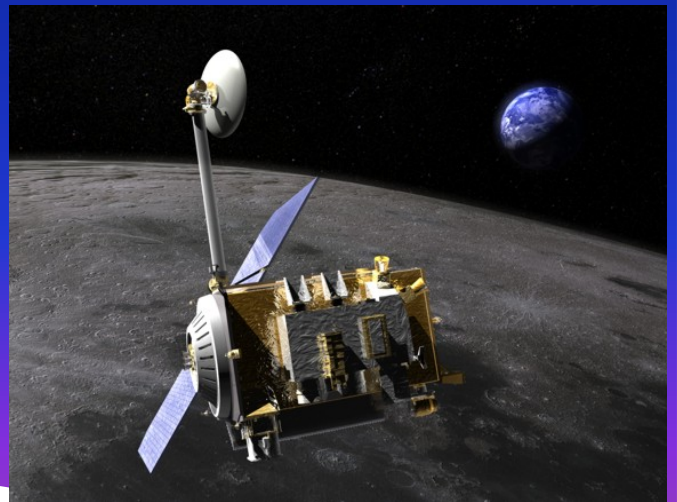
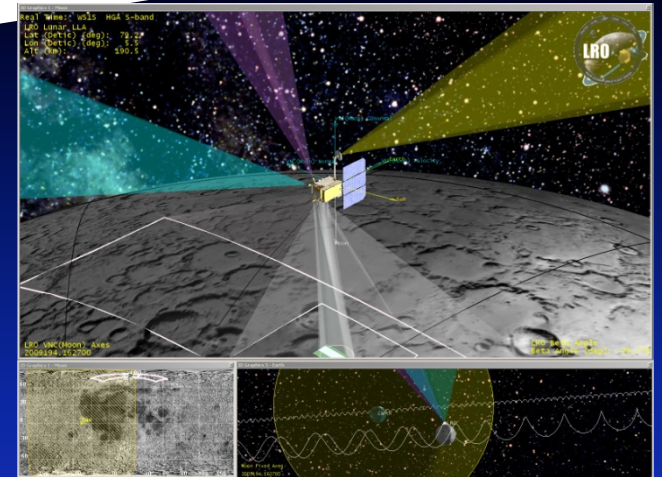

January 26, 2011

LRO Mission Objectives

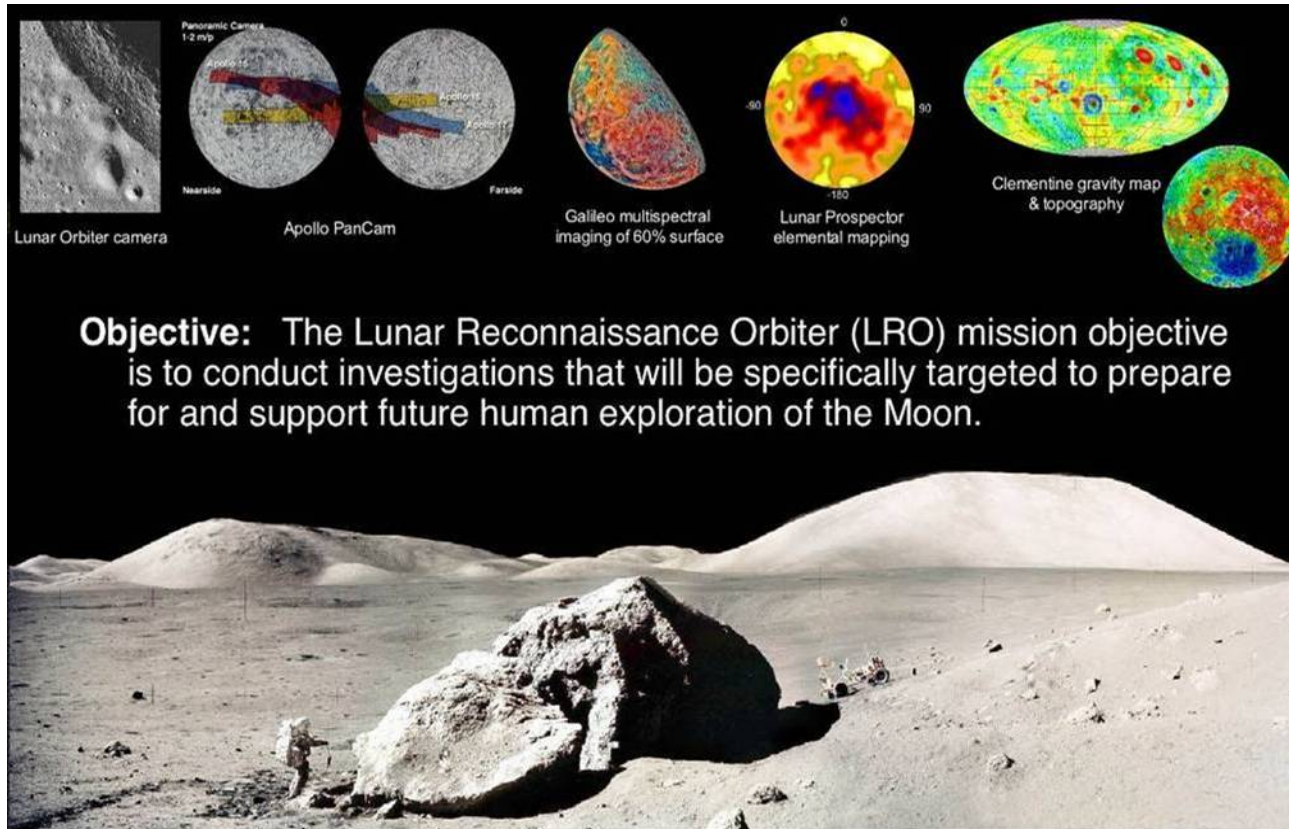

LOCATE RESOURCES

Hydrogen/water at the lunar poles
Continuous solar energy
Mineralogy

SAFE LANDING SITES

High resolution imagery
Global geodetic grid
Topography
Rock abundances

SPACE ENVIRONMENT

Energetic particles
Neutrons

LRO: The ESMD Mission

Goals: Locate resources

- Identify safe landing sites
- Measure the space environment
- Demonstrate new technology

Seven instrument payload

- Cosmic Ray Telescope for the Effects of Radiation (CRaTER)
- Lunar Orbiter Laser Altimeter (LOLA)
- LRO Camera (LROC)
- Lyman-alpha Mapping Project (LAMP)
- Diviner Lunar Radiometer Experiment (DLRE)
- Lunar Exploration Neutron Detector (LEND)
- Miniature Radio Frequency Technology Demonstration (Mini-RF)

LRO will return

- Global day/night temperature maps (DLRE)
- Global high accuracy geodetic grid (LOLA)
- High resolution black and white imaging (LROC)
- High resolution local topography (LOLA, LROC)
- Global ultraviolet map of the Moon (LAMP)
- Polar observations both in shadowed and illuminated areas (LEND, LROC, LOLA, DLRE, Mini-RF, LAMP)
- Ionizing radiation measurements in the form of energetic charged particles and neutrons (CRaTER, LEND)

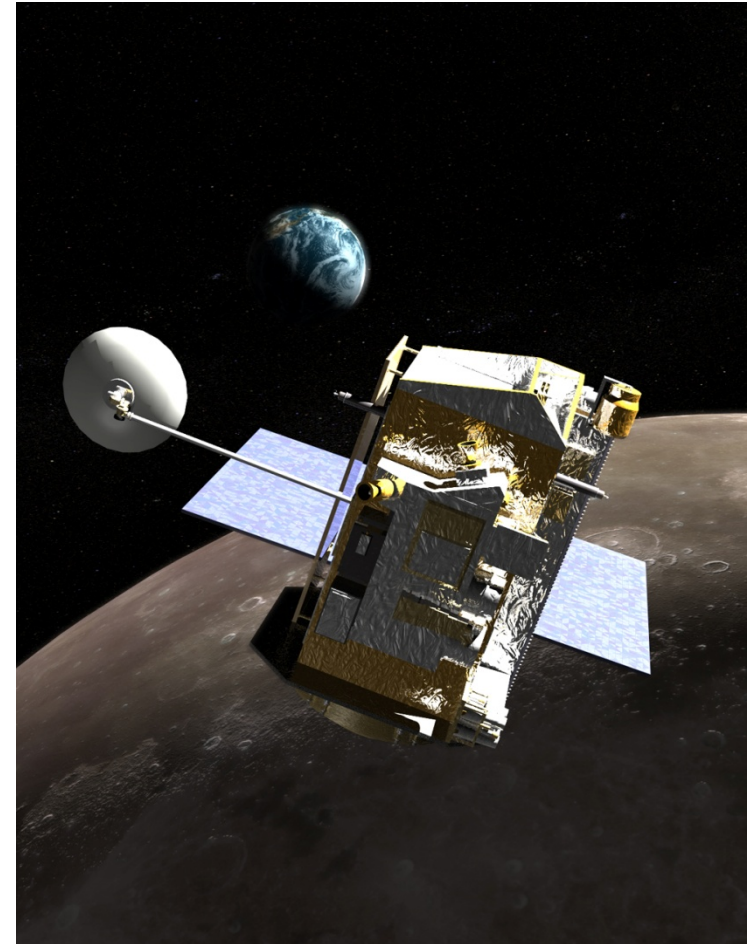

LRO Launched June 18, and entered mapping orbit September 15, 2009

LRO has robust and resilient capabilities

	<u>Objectives</u>	<u>LRO Requirements</u>	<u>Contributing Instruments</u>
1	Find Safe Landing Sites	Global geodetic grid 10 cm vertical, and at the poles, 50 m horizontal resolution	LOLA, LROC
		Identify surface features & hazards	LROC, LOLA, DLRE
2	Locate Potential Resources	Provide lunar temperature map from 40 - 300K, 5 K precision over full diurnal cycle.	DLRE
		Image the permanently shadowed regions.	LAMP, LOLA
		Identify putative deposits of water-ice	LAMP, LEND, LOLA
		Characterize the polar region illumination environment	LROC, LOLA, DLRE
		Characterize lunar mineralogy	LROC, DLRE
		Hydrogen mapping	LEND
3	Life in the Space Environment	Characterize the deep space radiation environment at energies in excess of 10 MeV	CRaTER, LEND
		Measure the deposition of deep space radiation on human equivalent tissue.	CRaTER
4	New Technology	Technology demo	Mini-RF

LRO Mission Overview

- Launched on an Atlas V into a direct insertion trajectory to the Moon. Co-manifested with LCROSS lunar impactor mission.
- On-board propulsion system used to capture at the Moon, insert into and maintain 50 km mean altitude circular polar orbit.
- Orbiter is 3-axis stabilized, nadir pointed, operates continuously during the primary mission.
- Data products delivered to Planetary Data Systems (PDS).
- Launched on June 18, 2009.
- Began Exploration orbit on September 15, 2009.
- Will complete Exploration mission and start Science mission on September 15, 2010.

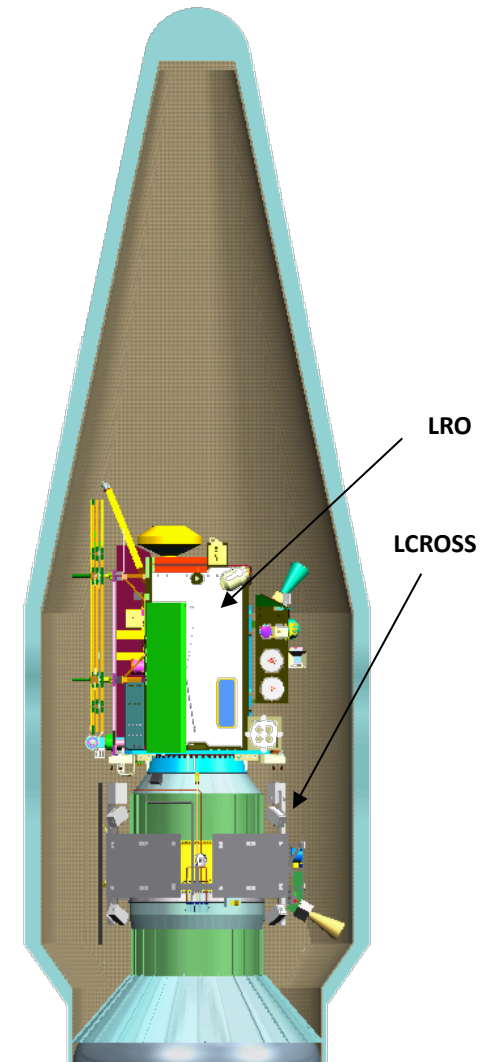

ESMD Operational Phases

- **Four day cruise to Lunar Orbit Insertion**
- **Two month commissioning phase**
 - Spacecraft and instrument check out
 - Low energy elliptical orbit 30 x 216 km orbit, periapsis at south pole
- **Twelve month Exploration Mission**
 - Near-circular 50 x 50 km orbit
 - Decays to 35 x 65 km in one month
 - Re-initialized every month (11 m/sec ΔV)

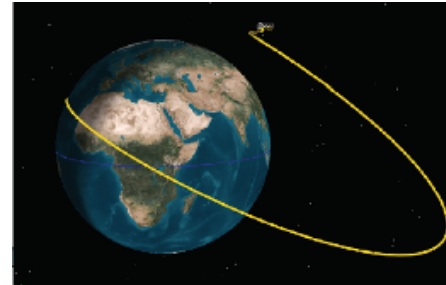

Minimum Energy
Lunar Transfer ~ 4 Days

Lunar Orbit Insertion
Sequence, 4-6 Days

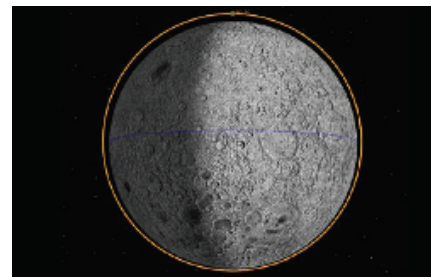
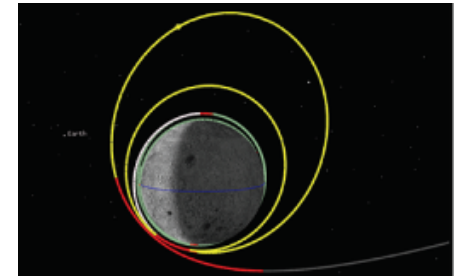

Commissioning Phase,
30 x 216 km Altitude
Quasi-Frozen Orbit,
60 Days

Polar Mapping Phase,
50 km Altitude Circular Orbit,
At least 1 Year

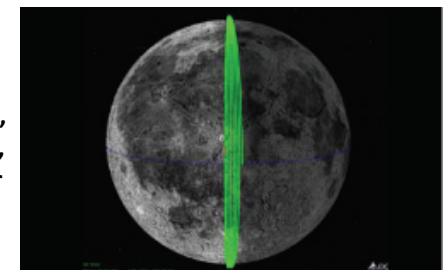

ESMD Mission Success

- ESMD Level-1 data acquisition requirements for Minimum Mission Success were accomplished in March, 2010
- ESMD Level-1 data acquisition requirements for Full Mission Success were accomplished September 15, 2010
- All LRO measurement teams will be able to deliver final Exploration data products to ESMD by March 15, 2011. They are fully funded by ESMD to do so

The LRO Science Mission

- At SMD request, in January the LRO Science Team submitted a proposal for a two-year Science Mission to SMD. That proposal was favorably assessed by a Senior Review Panel
- The LRO Science Team then developed a Science Mission plan that is consistent with the priorities identified by the Senior Review Panel and feasible with the resources available to the LRO mission
- SMD approved the LRO Science Plan on August 9, 2010
- LRO Science Mission will run thru at least September 2012

Objectives of the LRO Science Mission

1. Investigate the bombardment history of the Moon, including basin-forming events and modern impact processes
2. Investigate lunar geologic processes and their role in the evolution of the lunar crust and shallow lithosphere
3. Investigate the processes that have shaped the global lunar regolith
4. Investigate and quantify the types, sources, sinks, and transfer mechanisms associated with volatiles on the Moon with emphasis on the polar regions
5. Investigate how the space environment interacts with the lunar surface on diurnal, seasonal, and yearly time scales

LRO Science Mission Operations

- LRO will stay in the 50-km orbit for approximately 10 months and then move to a Transition Orbit for about 250 days (an elliptical orbit with a migrating line of apsides). Eventually LRO will move to the Frozen Orbit (30x216 km) that was used for the ESMD Commissioning Phase.
- All LRO data products will be delivered to the Planetary Data System within six months for use in scientific and exploration studies
- ESMD will benefit from the Science Mission observations:
 - Improved sensitivity (e.g. LEND, LAMP)
 - Greater spatial coverage (e.g. LOLA, DLRE)
 - Additional observations of Exploration Regions of Interest
 - Measurements of solar energetic particles with increasing solar activity

LRO Instruments and Investigations

LOLA: Lunar Orbiter Laser Altimeter
 PI: David Smith, GSFC/MIT; Co-PI: Maria Zuber, MIT

- Topography
- Slopes
- Roughness



Deliverables:
 ~50m scale topography at
 <1m vertical, roughness

LROC/WAC: Wide-Angle Camera
 PI: Mark Robinson, ASU

- Global Imagery
- Lighting
- Resources

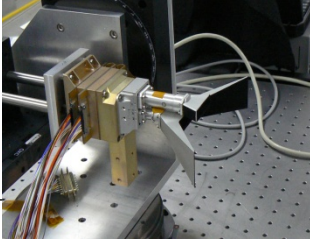

Deliverables :
 Entire Moon at 100m in UV,
 Visible (time series)

LROC/NACs: Narrow Angle Cameras
 PI: Mark Robinson, ASU

- Targeted Imagery
- Hazards
- Topography

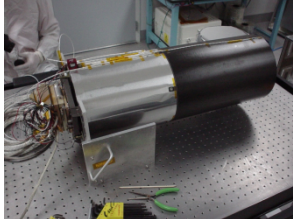

Deliverables :
 1000's of 50 cm/pixel images
 (125 km²)

LR: Laser Ranging
 PI: David Smith, GSFC/MIT; Co-PI: Maria Zuber, MIT

- Topography
- Gravity



Deliverables:
 Precision orbit
 determination

DLRE: Diviner Lunar Radiometer Experiment
 PI, David Paige, UCLA

- Temperature
- Lighting
- Hazards
- Resources



Deliverables:
 ~300m scale maps of
 temperature, cold traps, and
 rocks

Mini-RF: Synthetic Aperture Radar
 PI: Ben Bussey, APL

- Tech Demonstration
- Resources
- Topography



Deliverables:
 Stokes parameter SAR
 images

CRaTER: Cosmic Ray Telescope...
 PI: Harlan Spence, UNH

- Radiation Spectra
- Tissue Effects

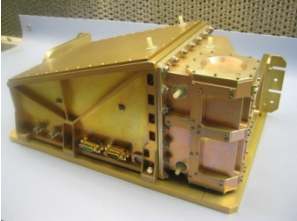

Deliverables:
 Linear Energy Transport
 Spectra

LEND: Lunar Exploration Neutron Detector
 PI: Igor Mitrofanov, IKI; DPI: Roald Sagdeev, UMD

- Neutron Albedo
- Hydrogen Maps



Deliverables:
 Maps of polar hydrogen in
 upper m of Moon at ~10km

LAMP: Lyman-Alpha Mapping Project
 PI: Alan Stern, SwRI

- Water-Frost
- PSR Maps



Deliverables:
 Maps of frosts in
 permanently shadowed
 areas, etc.

LRO Spacecraft and Instruments

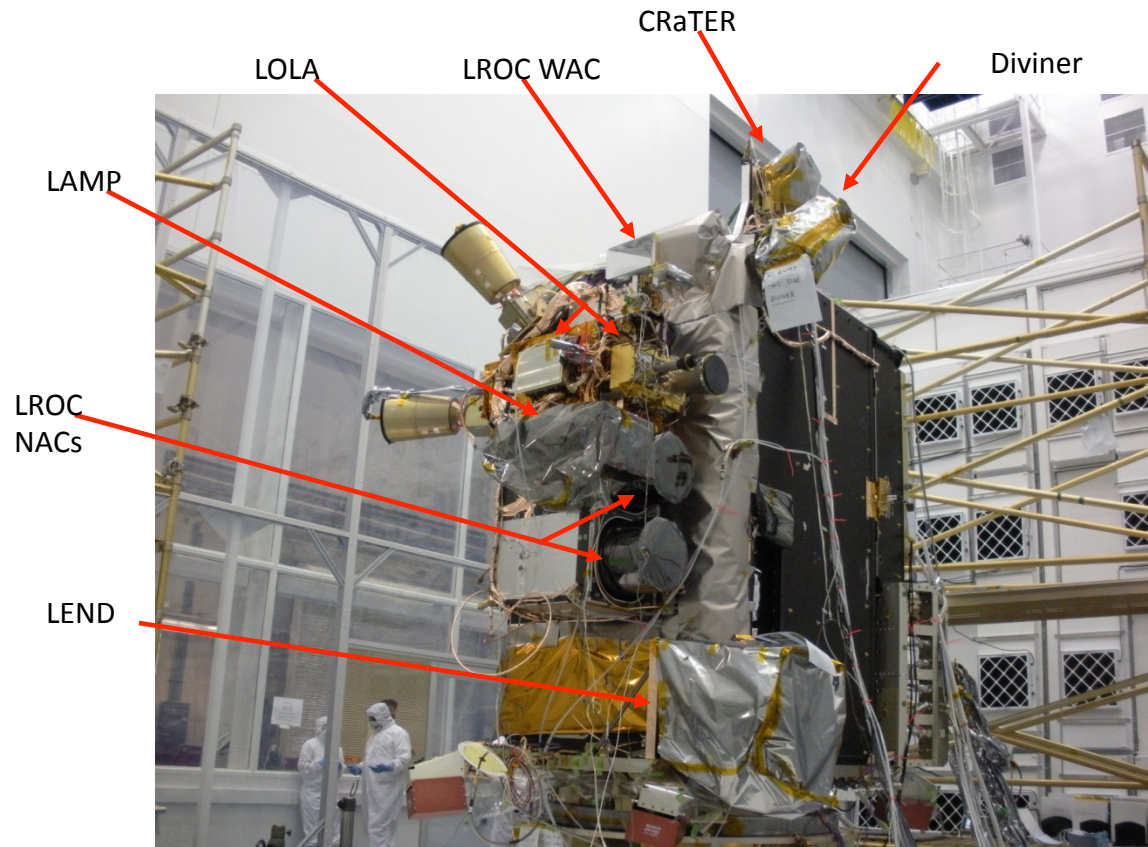

Lunar Reconnaissance Orbiter Camera (LROC)

Mark Robinson PI, ASU - SOC at ASU

<http://lroc.sese.asu.edu/>

Wide and Narrow Angle Cameras (WAC, NAC)

- Landing site identification and certification, with unambiguous identification of meter-scale hazards.
- Meter-scale mapping of polar regions with continuous illumination.
- Unambiguous mapping of permanent shadows and sunlit regions including illumination movies of the poles.
- Overlapping observations to enable derivation of meter-scale topography.
- Global multispectral imaging to map ilmenite and other minerals.
- Global morphology base map.
- NAC pixel dimension of 50 cm from 50 km.
- WAC pixel dimension of 100 m from 50 km.
- Images geodetically tied to LOLA

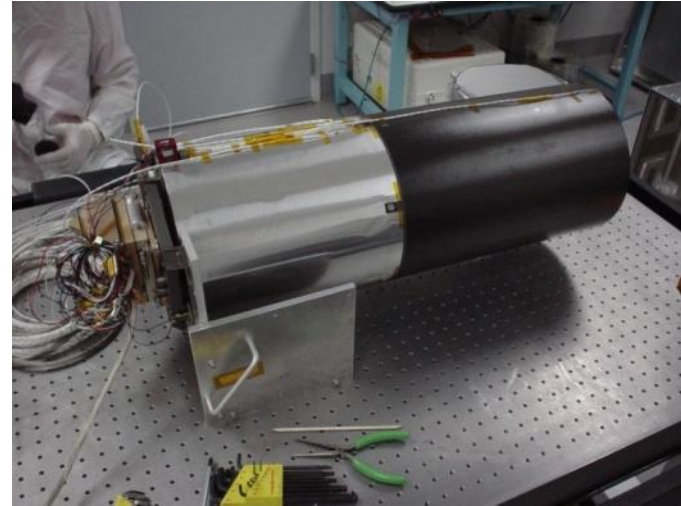

NAC

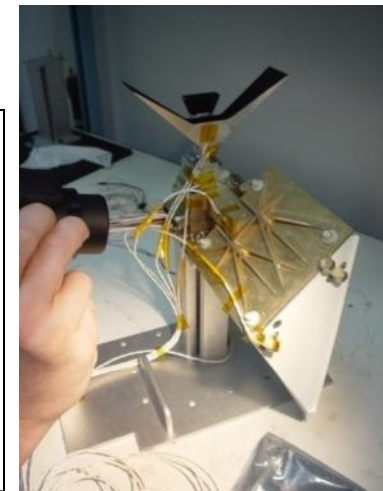

WAC

WAC Filters
#1 – 315 nm
#2 - 360 nm
#3 - 415 nm
#4 - 560 nm
#5 - 600 nm
#6 - 640 nm
#7 - 680 nm

LROC Providing a Wealth of Lunar Data

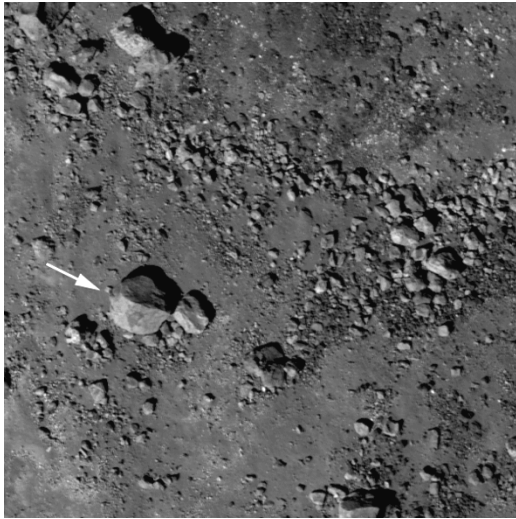

Boulders on floor of Aristarchus – 35 m
arrowed peak



Apollo 14 landing site

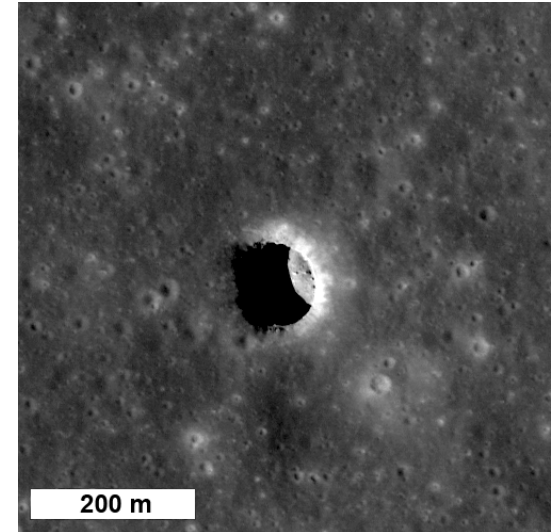

Mare Pit Craters

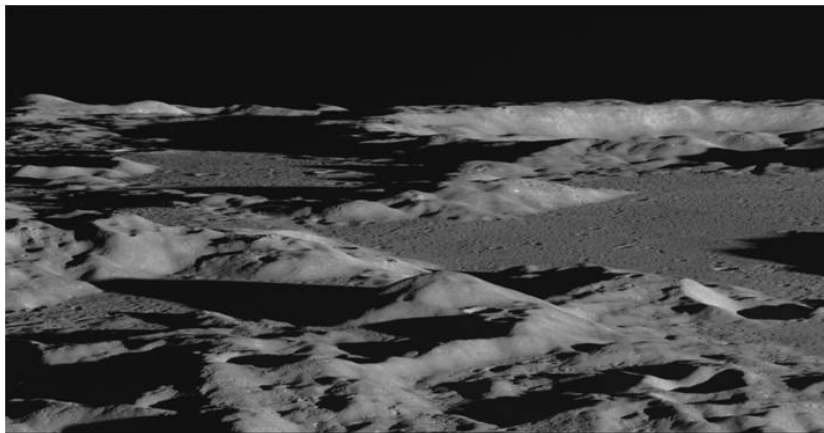

LROC – North Polar Oblique

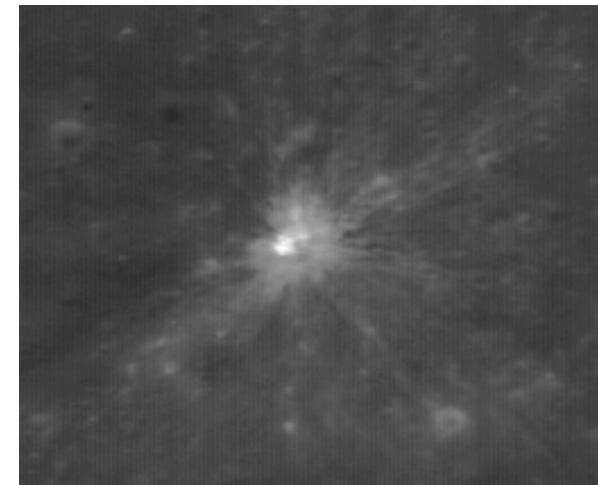

New crater ~10 m diameter

Luna 21 and Lunokhod 2

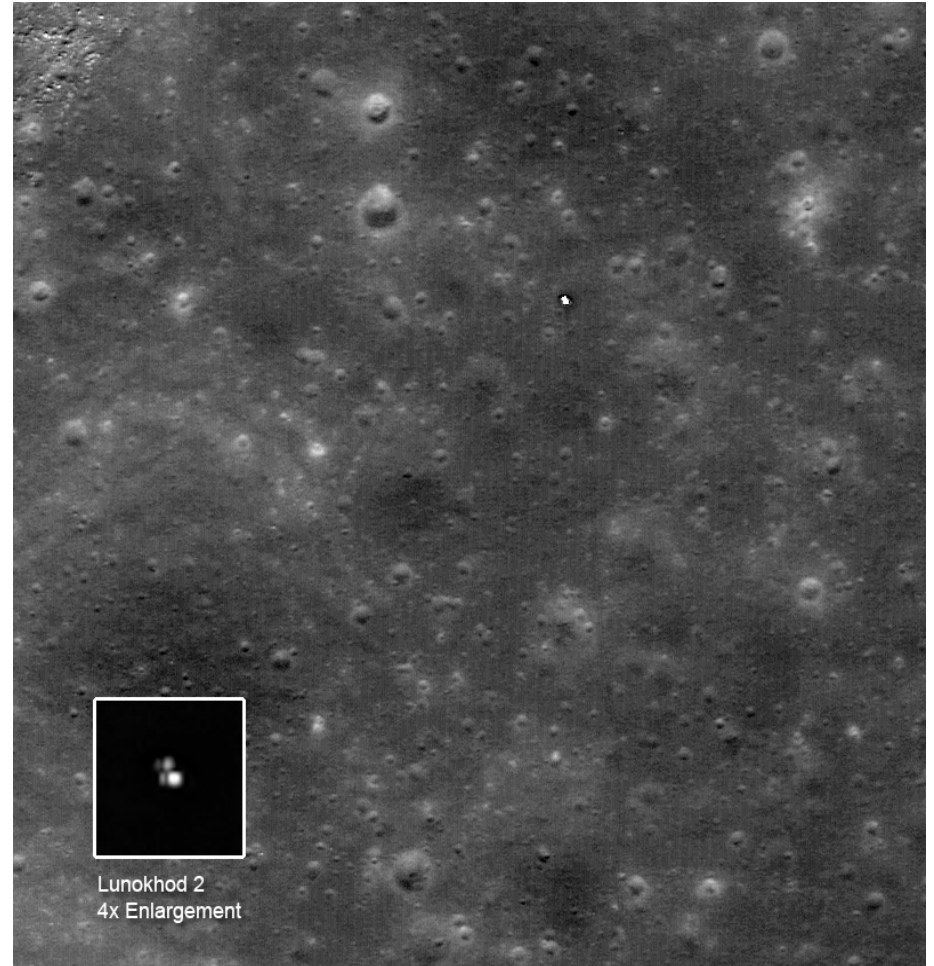
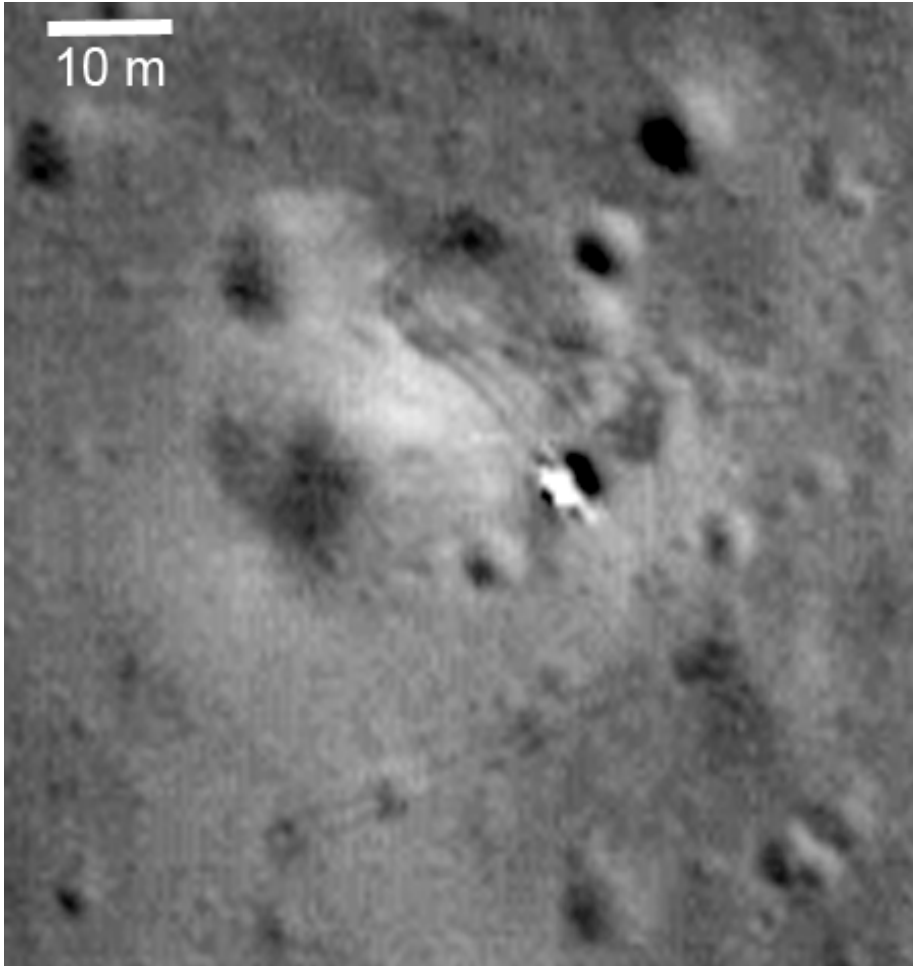

Lunar Orbiter Laser Altimeter (LOLA)

Dave Smith PI, GSFC/MIT; Maria Zuber D-PI, MIT; SOC at GSFC

<http://lunar.gsfc.nasa.gov/lola/>

- LOLA is a geodetic tool to derive a precise positioning of observed features with a framework (grid) for all LRO Measurements
- **LOLA measures:**
 - RANGE to the lunar surface (pulse time-of-flight) $\pm 10\text{cm}$ (flat surface)
 - REFLECTANCE of the lunar surface (Rx Energy/Tx Energy) $\pm 5\%$
 - SURFACE ROUGHNESS (spreading of laser pulse) $\pm 30\text{ cm}$
- **Laser pulse rate 28 Hz, 5 spots**
=> ~ 4 billion measurements in 1 year.
- LOLA will obtain an **accuracy base** of ~ 50 meters horizontal (point-to-point) and 0.5 to 1 meter radial
 - Laser ranging from ground station to LRO provides **precise orbit determination**

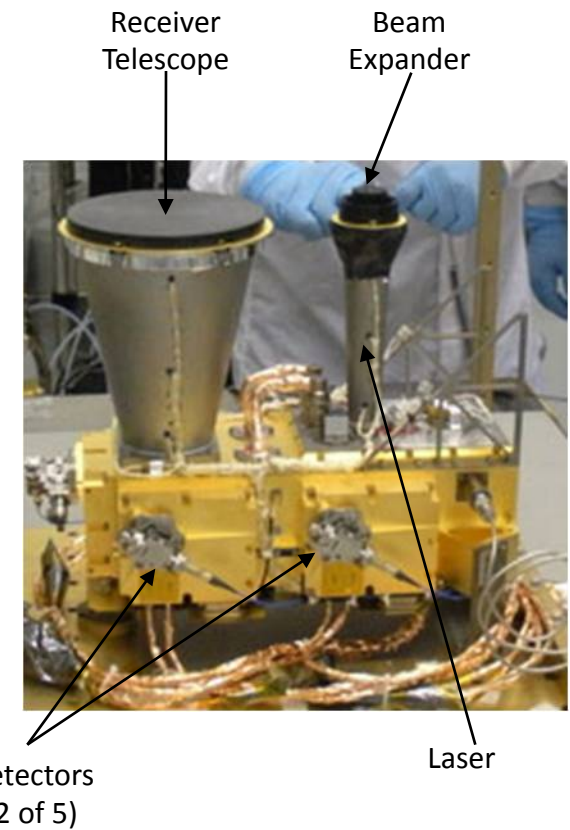
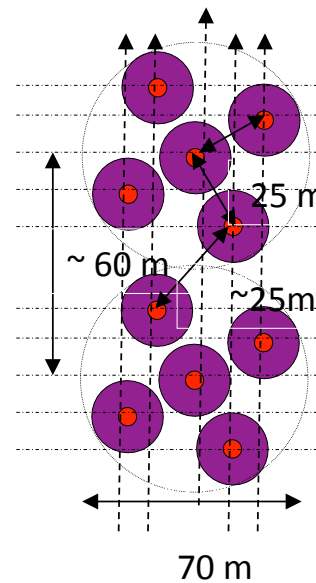

Laser Ranging from Earth to LRO via LOLA

Earth-based laser tracking stations are successfully ranging to LRO via LOLA for improved LRO timing and orbit determination

LR: 10-cm range precision 28 Hz, 532 nm

LOLA: 10-cm range accuracy 28 Hz, 1064 nm

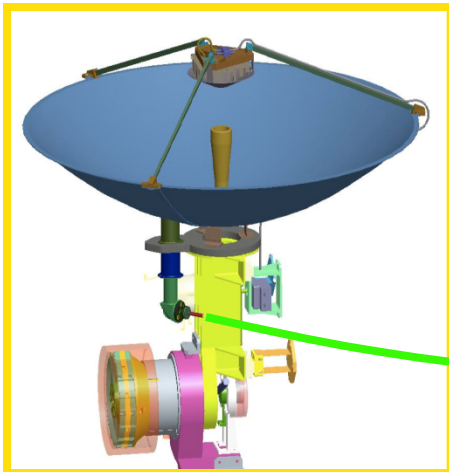

10-m fiber optic bundle carries LR Earth laser signal to LOLA channel-1 detector

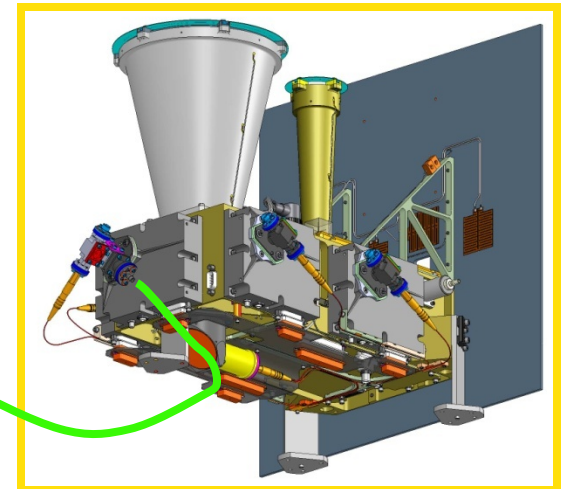

LOLA Global Topography

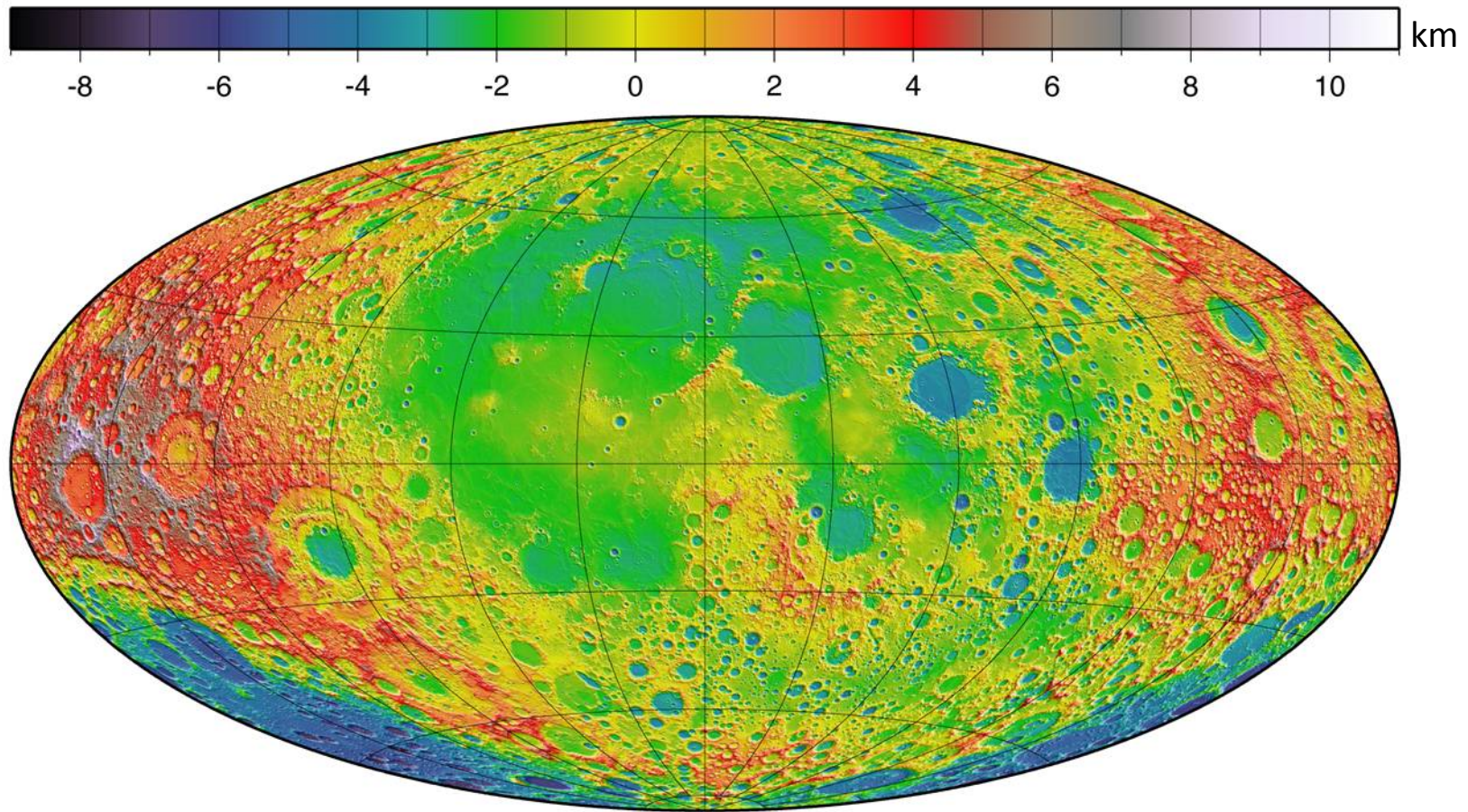

Equal-Area projection of lunar topography developed from 1 billion LOLA measurements.
Resolution: N/S \sim 20 meters; E/W \sim 0.1° (4.5 km at equator, 200 m at lat 85°)
(vertical precision 1-2 m)

Diviner Lunar Radiometer (DLRE)

David Paige PI, UCLA - SOC at JPL and UCLA
<http://www.diviner.ucla.edu/>

- Diviner will characterize the moon's surface thermal environment (day and night)
- Surface properties will be mapped
 - *Bulk thermal properties (from surface temperature variations)*
 - *Rock abundance and roughness (from fractional coverage of warm and cold material)*
 - *Silicate mineralogy (8 micron thermal emission feature)*
- The characteristics of the polar cold traps will be determined
 - *Map cold-trap locations*
 - *Determine cold-trap depths*
 - *Assess feasibility of water ice resources (using data and models)*



- 9-channel infrared radiometer 40K – 400K temperature range
- 21 pixel continuous pushbroom mapping with ~300 m spatial resolution and 3.15 km swath width at 50 km altitude
- Azimuth and elevation pointing for off-nadir observations and calibration
- Close copy of JPL's Mars Climate Sounder (MCS) Instrument on MRO

DLRE Temperature Maps

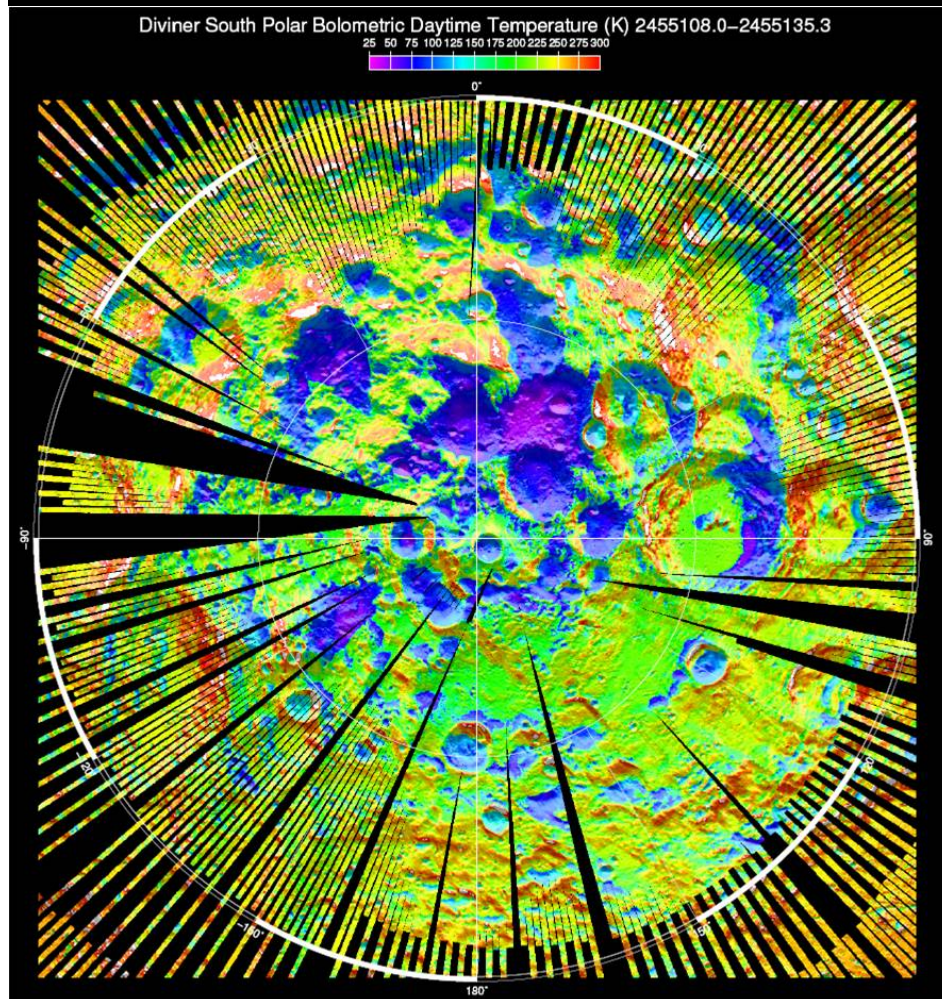

Data

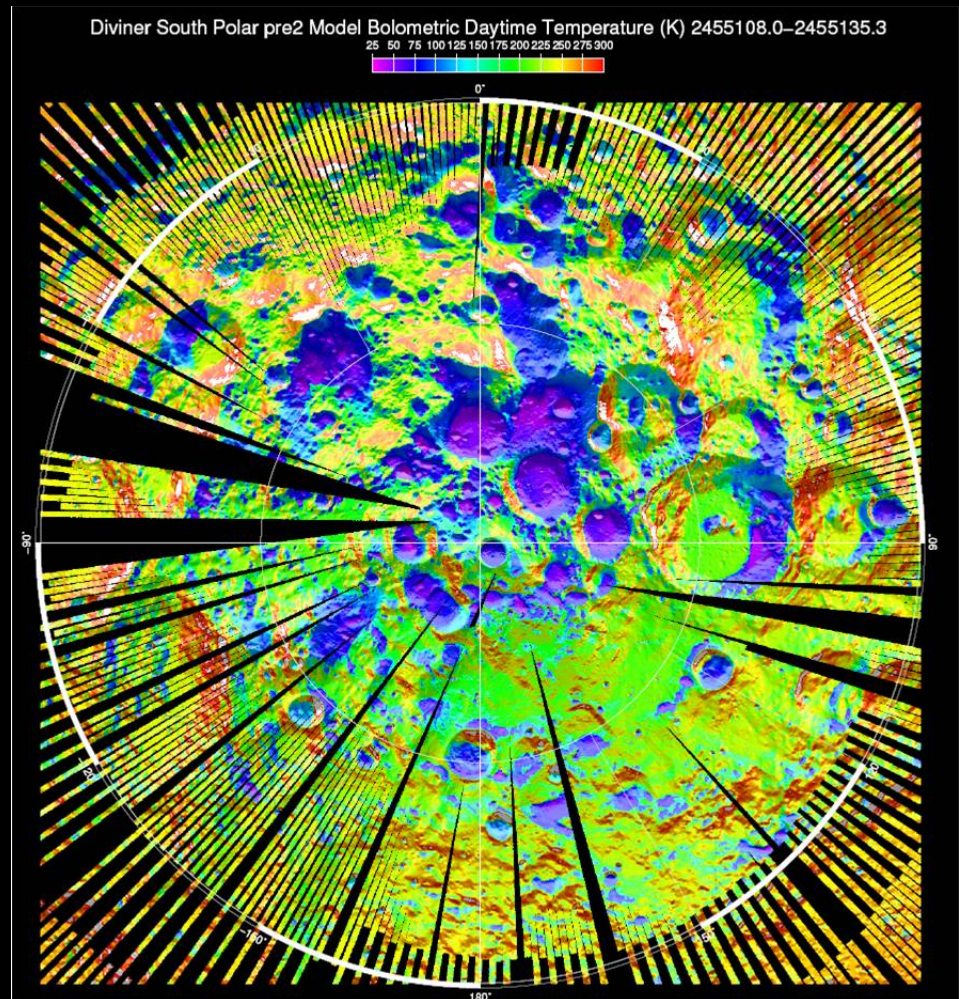

Model

South Pole Noon Solstice

Lunar Exploration Neutron Detector (LEND)

Igor Mitrofanov PI, IKI – SOC at UAz, GSFC, IKI

http://ps.iki.rssi.ru/lend_en.htm

- LEND is designed to measure lunar thermal, epithermal and energetic neutrons.
- LEND improves spatial resolution for epithermal neutrons from 140km to 10km to locate areas of high hydrogen concentration
- LEND footprint smaller than the Permanently Shadowed Regions
- Improves sensitivity of hydrogen (water) measurements in upper meter of surface in cold spots
- Enables site selection



LEND has four collimated sensors for measurement of epithermal neutrons, and five other sensors for thermal and energetic neutron measurements.

LEND Measurements for Supporting LCROSS Impact Site Selection

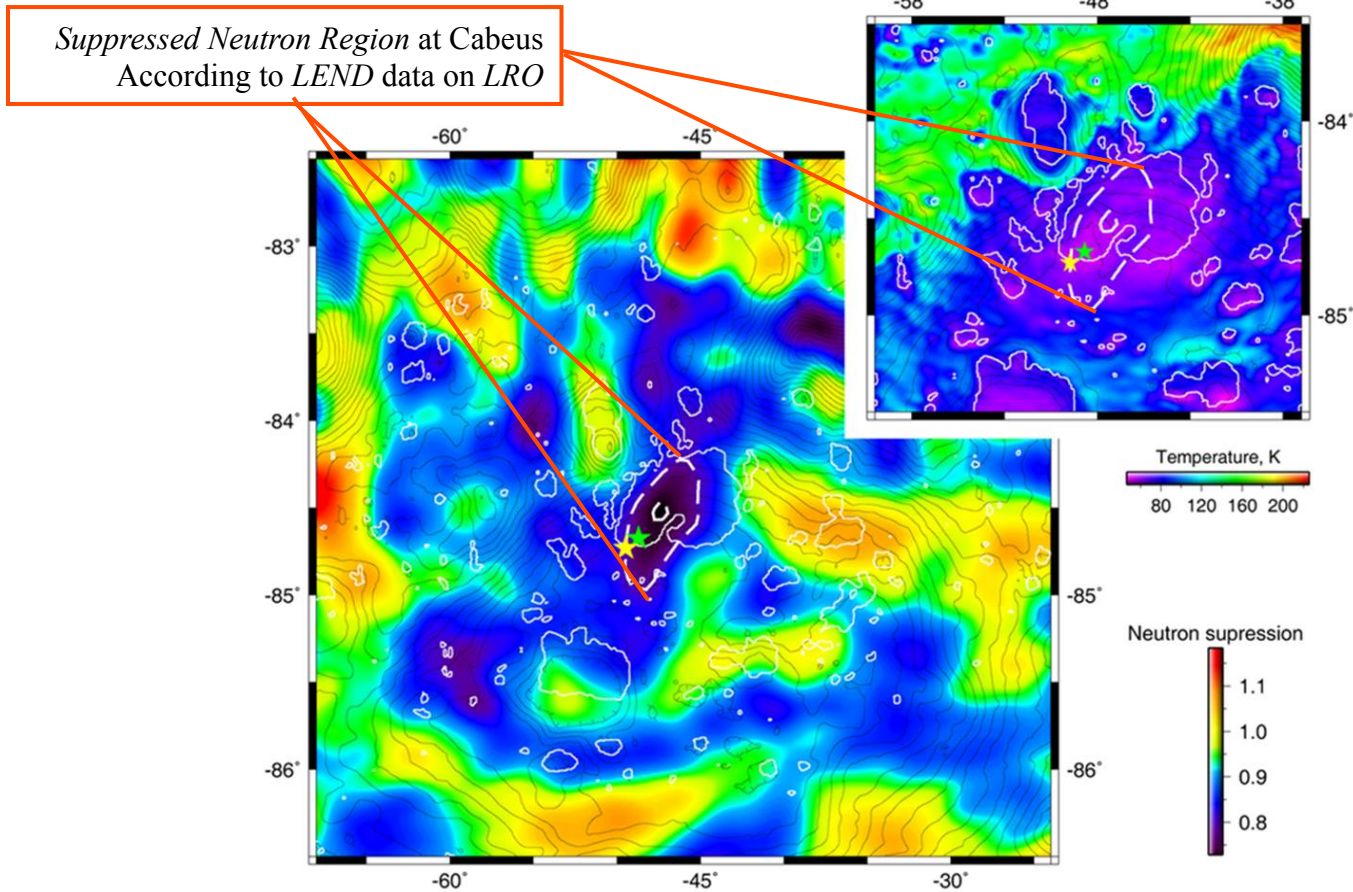

Stronger suppression of neutrons (*dark blue*) represents the enhancement of Hydrogen content within 1 meter top layer of the surface. Gray thin contours correspond to the surface relief, and white thin contours represent the *Permanently Shadowed Regions* (PSR) around Cabeus; these contours are derived from the altimetry data of *LOLA*. The insert at *right corner* shows the temperature map at the Cabeus vicinity according to *Diviner* measurements. *LCROSS* impact sites are shown for Centaur (yellow star) and shepherding spacecraft (green star).

Lyman-Alpha Mapping Project (LAMP)

Alan Stern, PI (SwRI); Randy Gladstone (SwRI), DPI – SOC at SwRI
<http://www.boulder.swri.edu/lamp/index.html>

- LAMP can identify and localize exposed water frost in permanently shadowed regions (PSRs) of the lunar surface PSRs
- LAMP provides landform mapping (using Ly α albedos) in and around the PSRs
- LAMP demonstrates the feasibility of using starlight and UV sky-glow for future night time and PSR surface mission applications.
- LAMP can measure the Lunar Atmosphere and Its Variability

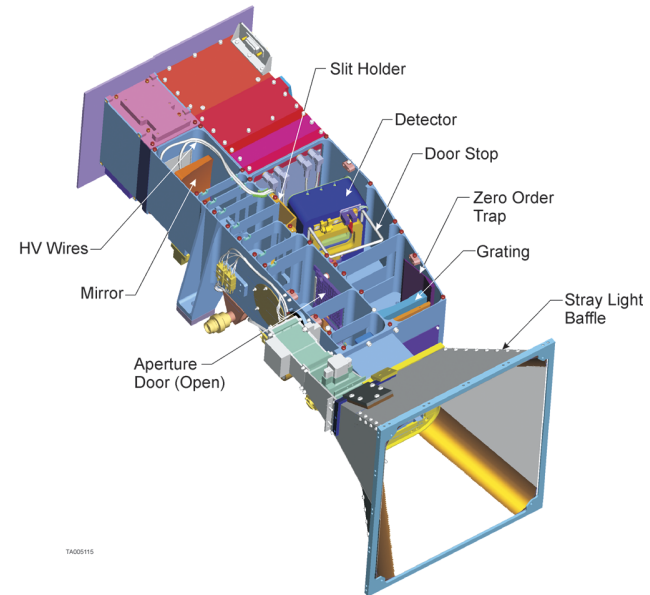

LAMP:
6.06 kg, 4.52 W
0.3°×6.0° slit
52-180 nm passband
<4 nm filled slit spectral resolution

LAMP South Pole Far UV Brightness Map

- Nightside mapping in reflected Lyman- α and starlight
- PSRs are noticeably darker than surrounding areas at Far UV wavelengths

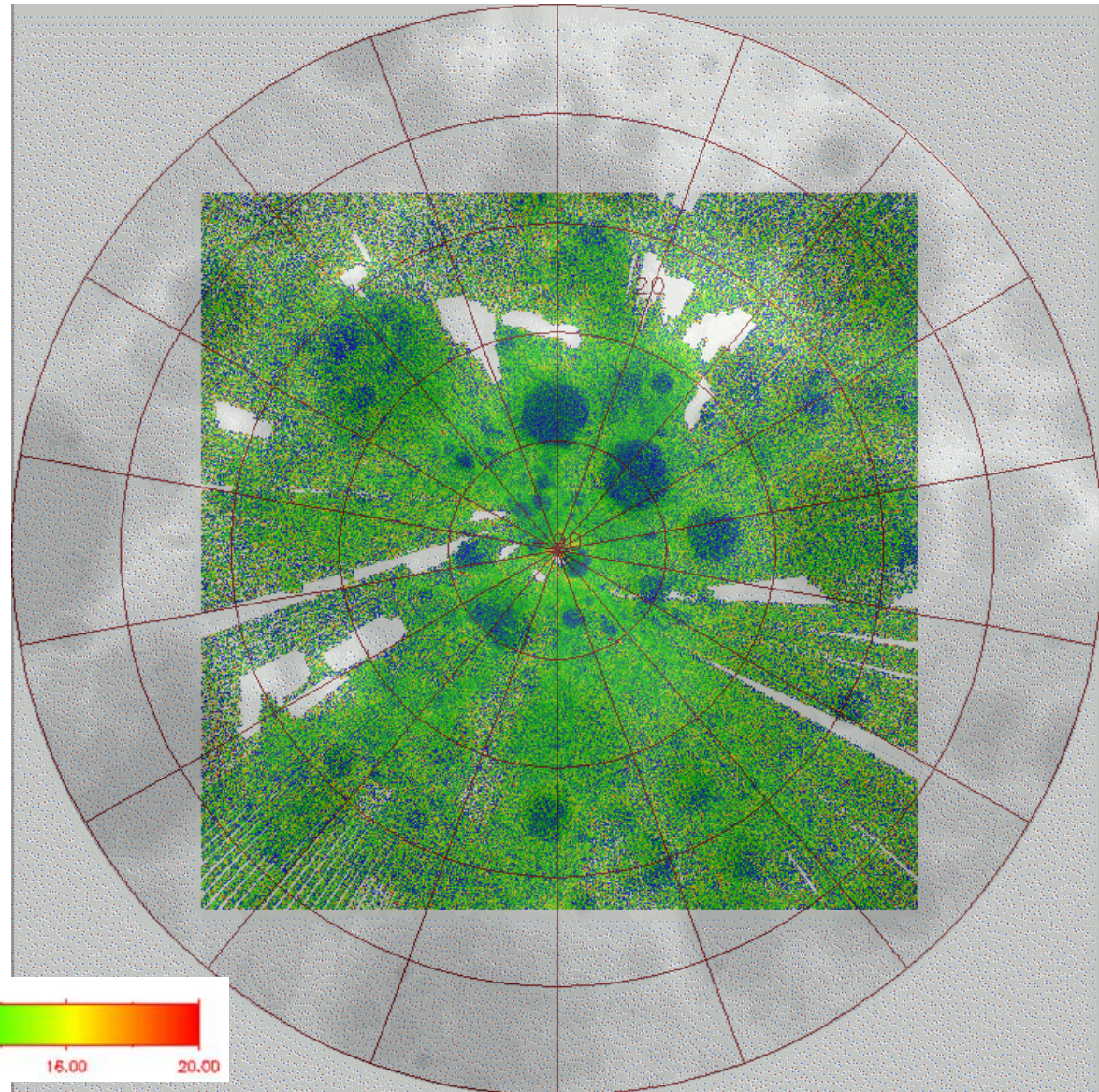

Cosmic Ray Telescope for the Effects of Radiation (CRaTER)

Harlan Spence PI, U. New Hampshire – SOC at UNH
<http://crater.sr.unh.edu/>

- CRaTER measures the Linear Energy Transfer (LET) spectra behind tissue equivalent plastic (TEP)
- LET spectra is the missing link connecting Galactic Cosmic Rays and Solar Energetic Particles to potential tissue damage
- Data is sorted by lunar phase and orbital location

- Nadir FOV: 75°, Zenith FOV: 35°
- Avg. Orbital Power Allocation: 9.0 W
- Mass Allocation: 6.36 kg
- Daily Data Volume: 7.8 Gbits (Flare)
- Data Collection: Full Orbit
- Inst. Daily Operations: Autonomous

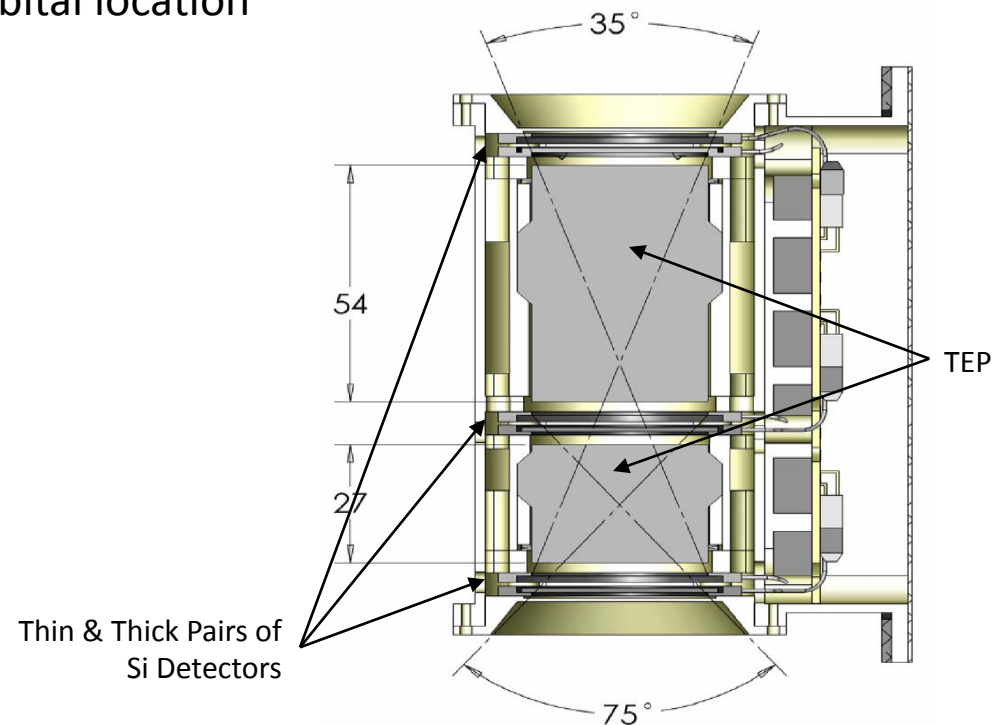

CRaTER – Observation of Excess Radiation from Lunar Surface

Moon blocks GCR, reducing radiation near surface, but secondary radiation source discovered, caused by GCR interactions with Moon

CRaTER Discovery of Proton Albedo

- **Secondary radiation from lunar surface**
- **Net radiation remains elevated**

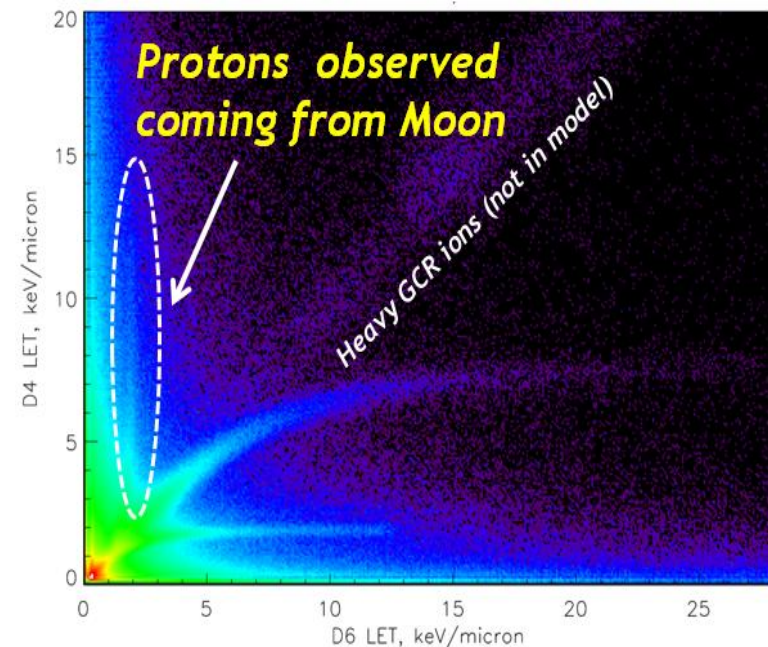

Miniature Radio Frequency Demonstration (Mini-RF)

Ben Bussey PI, APL – SOC at APL

Mini-RF Lunar Demonstrations
SAR Imaging (S-band and X-band)



Communications
Demonstrations
Component Qualification
X-Band Comm Demo



Monostatic imaging in S-
band and X-band to validate
ice deposits discoveries on
the Moon

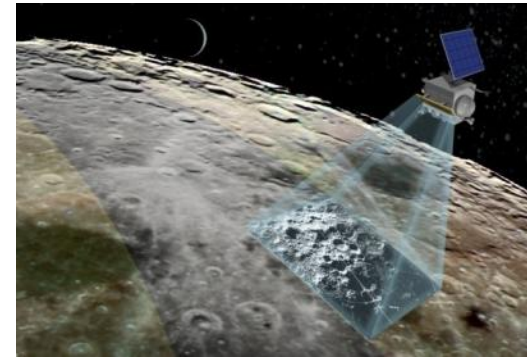

Imaging in S-band and X-
band to measure surface
regolith properties

Mini-RF radar mosaic of the Moon's north polar region (70°N to the pole)

- Mini-RF S-band radar in zoom has a surface resolution of 30 meters.
- The north polar mosaic shows the circular polarization ratio overlaid on top of radar reflectivity.
- Yellow and red areas indicate roughness at the 12 cm scale (e.g. ejecta blankets) while blue areas are relatively smooth.

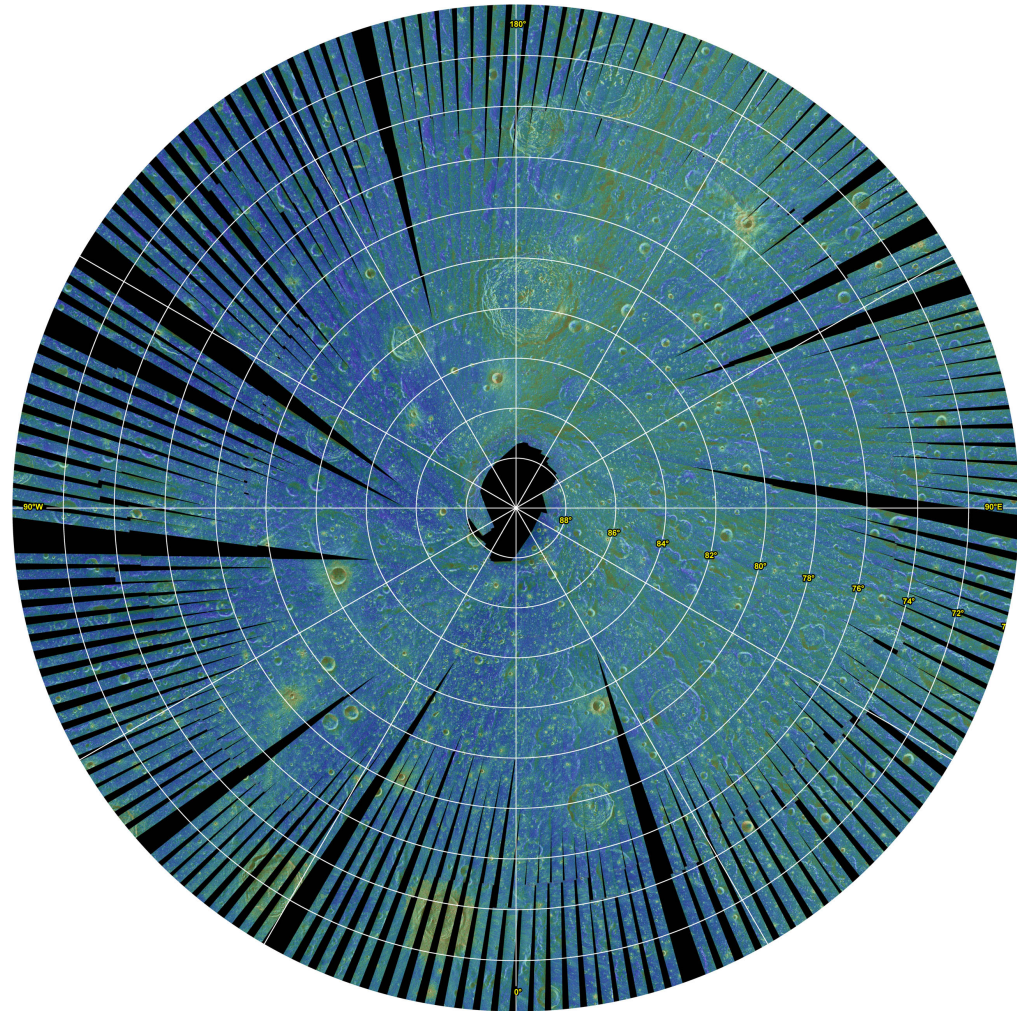

LCROSS Impact on October 9, 2009

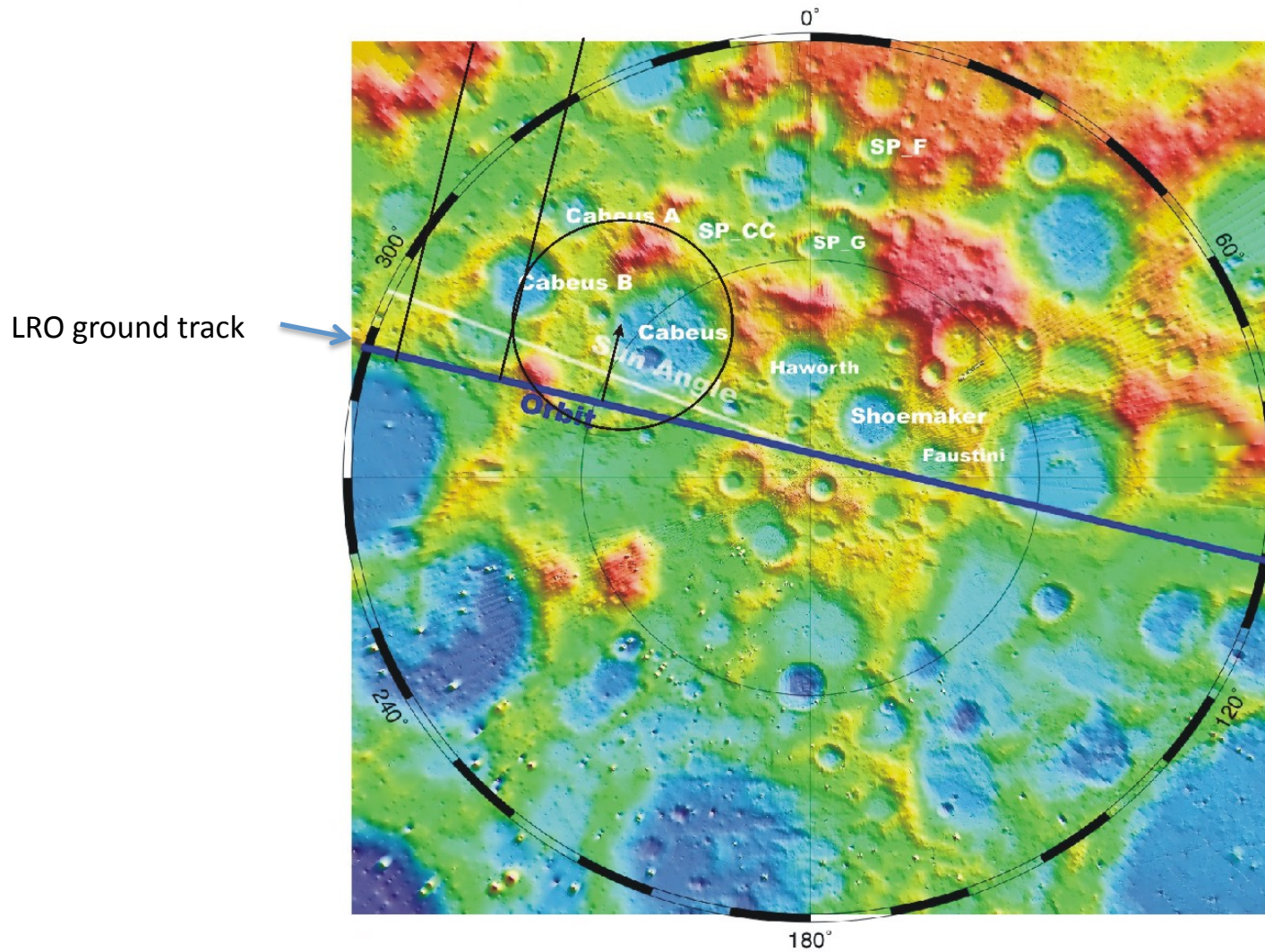

DLRE Observations of LCROSS Impact

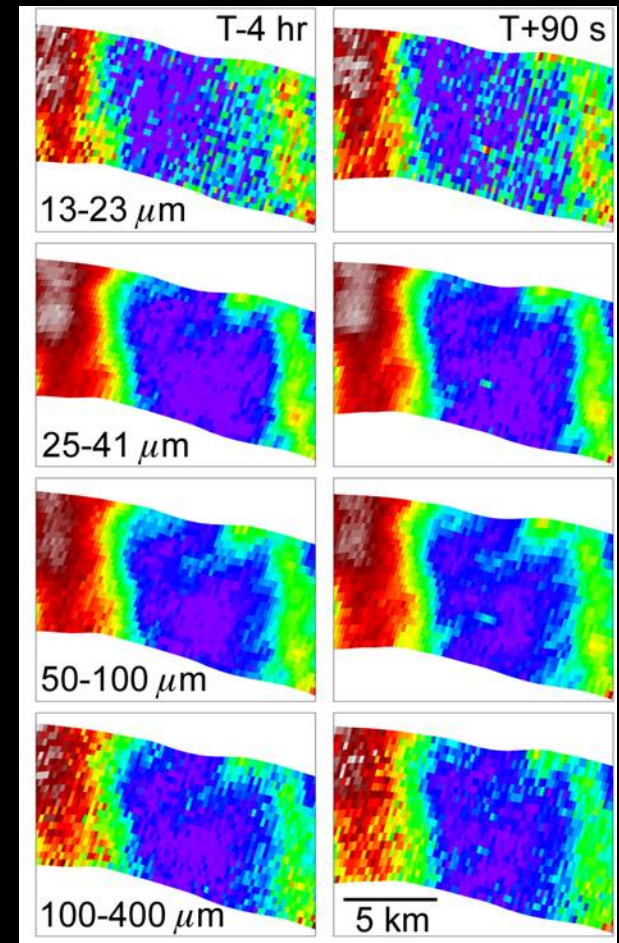
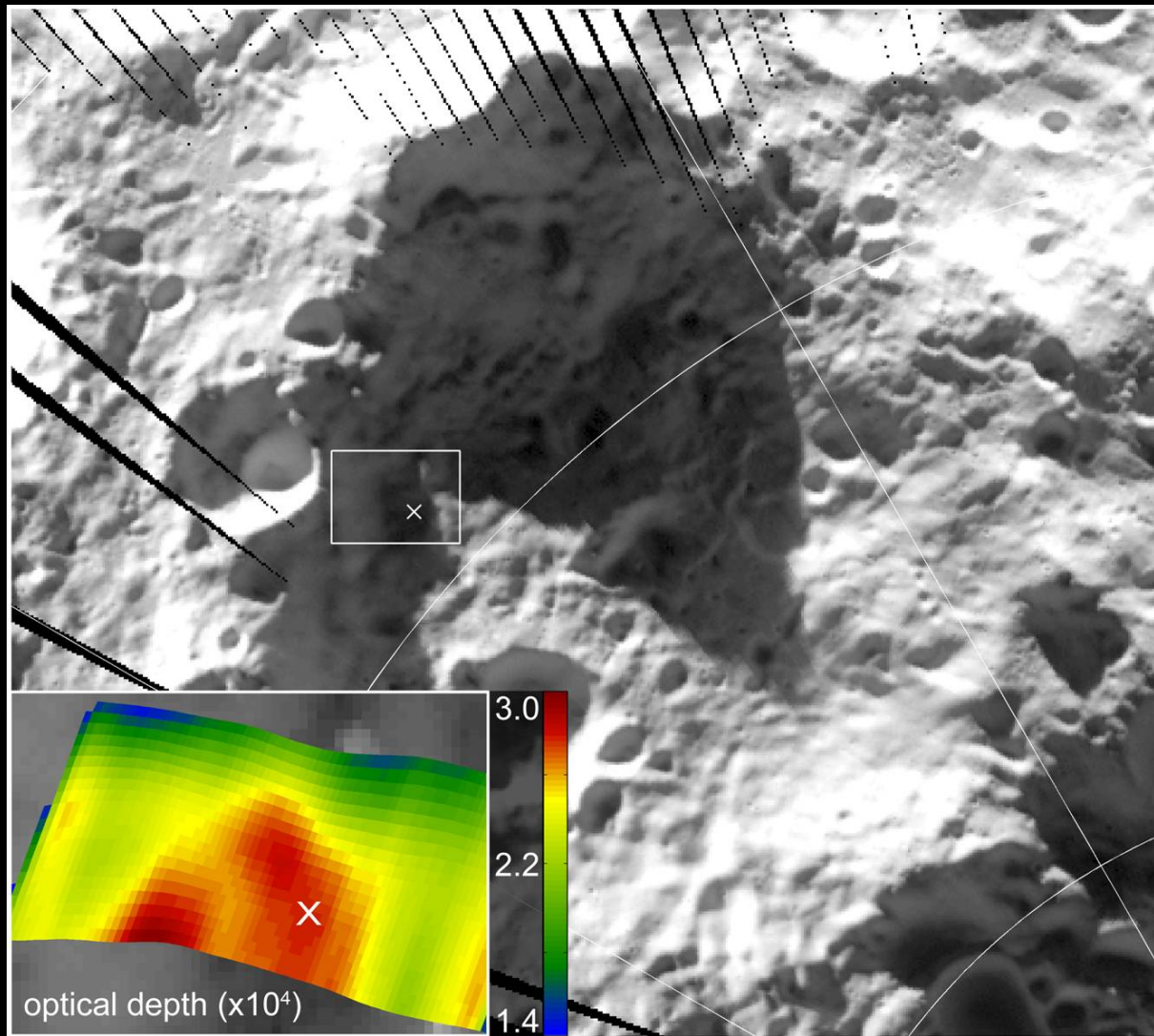

LAMP Observations of LCROSS Plume

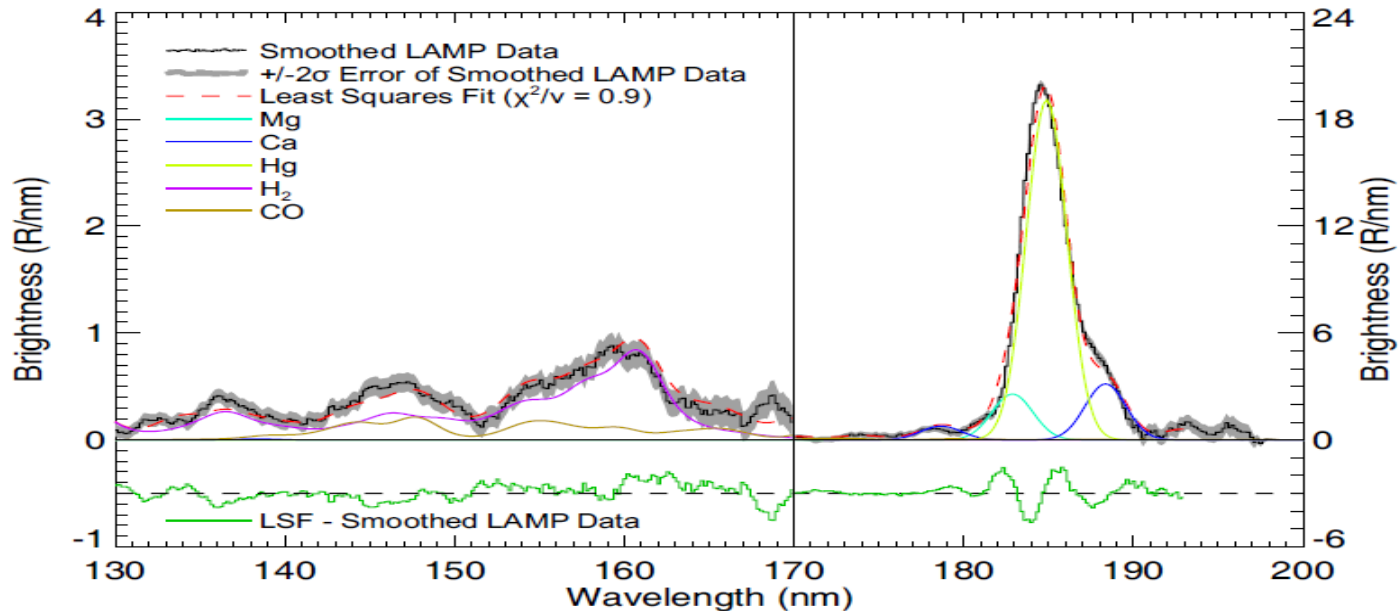

- The LAMP FUV spectrum is well fit by a combination of molecular hydrogen, carbon monoxide, and atomic mercury in gas form, with minor contributions from magnesium and calcium atoms
- These species were apparently released when the impacting LCROSS heated the soil to ~ 1000 K
- These results demonstrate that many other volatiles than just water are contained in the Moon's permanently shaded regions

Exploration Regions of Interest

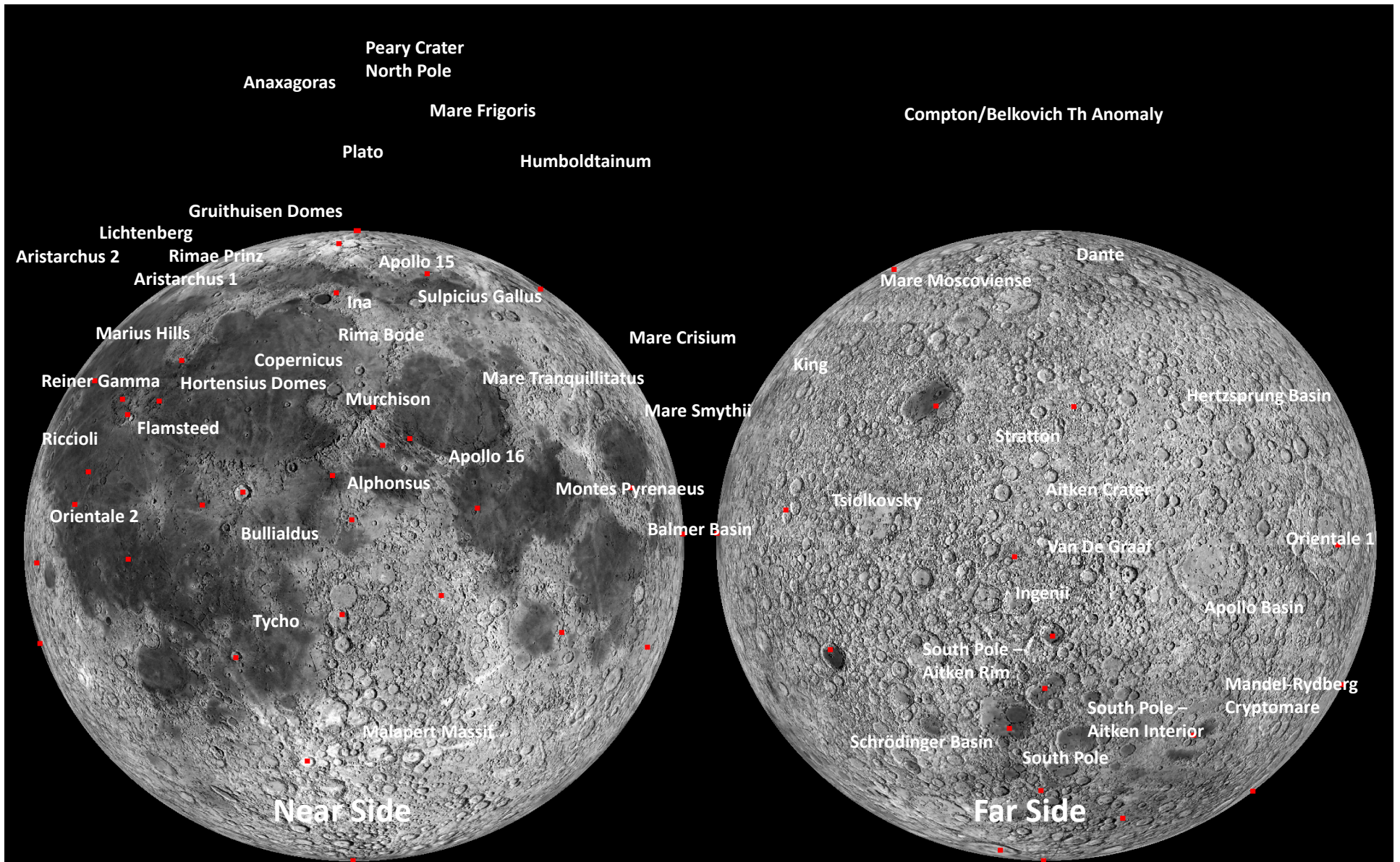

Observations of Exploration Regions of Interest

as of ~ 7/6/10

% coverage	10x10 km	20x20 km	40x40 km
95-100	47	38	8
75-95	3	12	19
50-75	0	0	21
25-50	0	0	2
0-25	0	0	0

LRO Data Distribution through the Planetary Data System

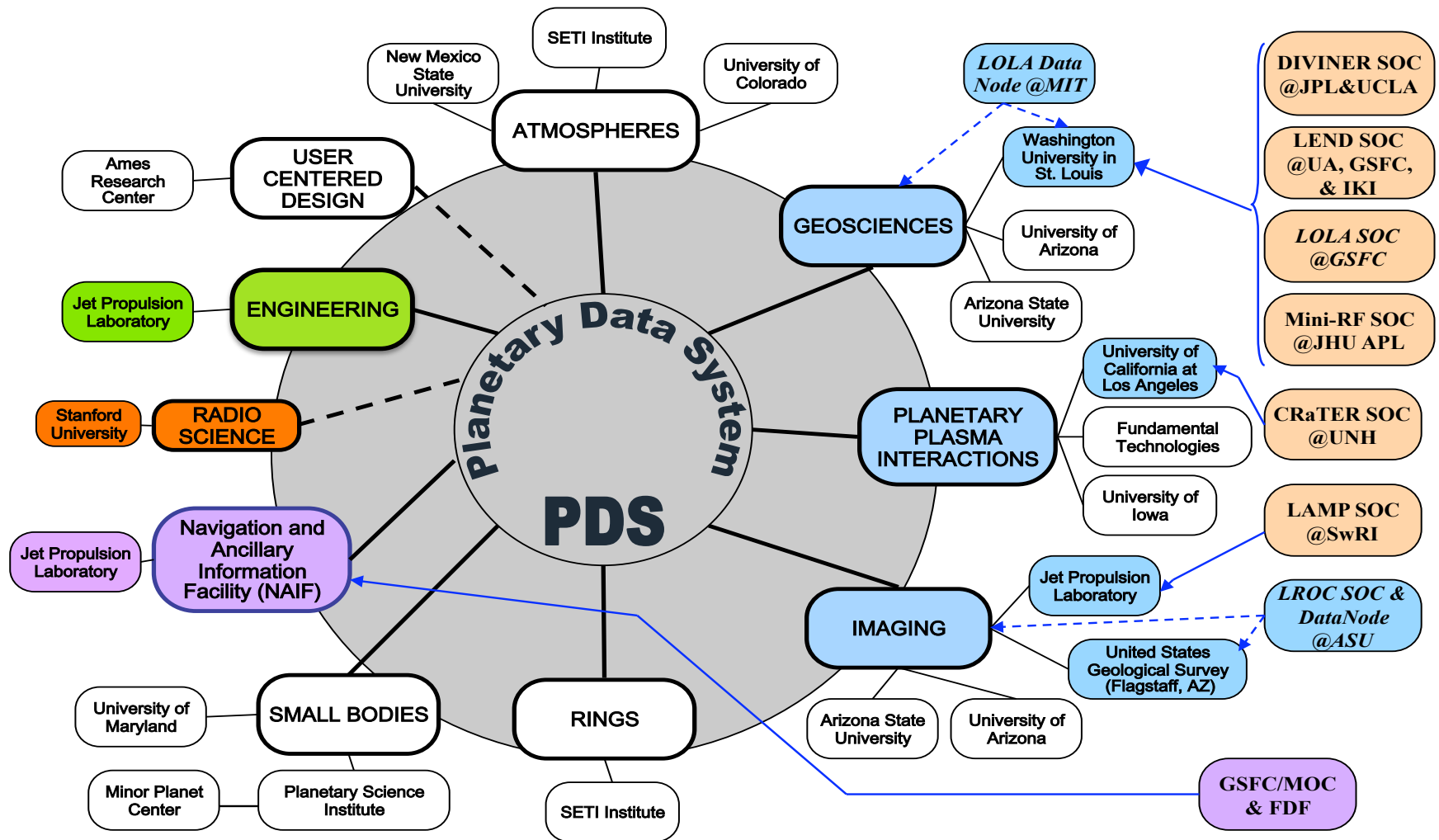

Color and font scheme: blue for LRO data archive and distribution- PDS Nodes (e.g., Geosciences) and Data Nodes (e.g., LROC)- all archive and distribute data; tan for LRO SOC (except LROC); purple for LRO SPICE data; green for PDS system-wide engineering; orange for PDS Sub-node with LRO advisory role. LRO SOC Data Node names are in italics.

LRO Data Delivery Schedule

SOCs deliver 3-6 month old, validated, initial version of LRO data to PDS every 3 months, starting 6 months after Initial Operations on 9/15/09.

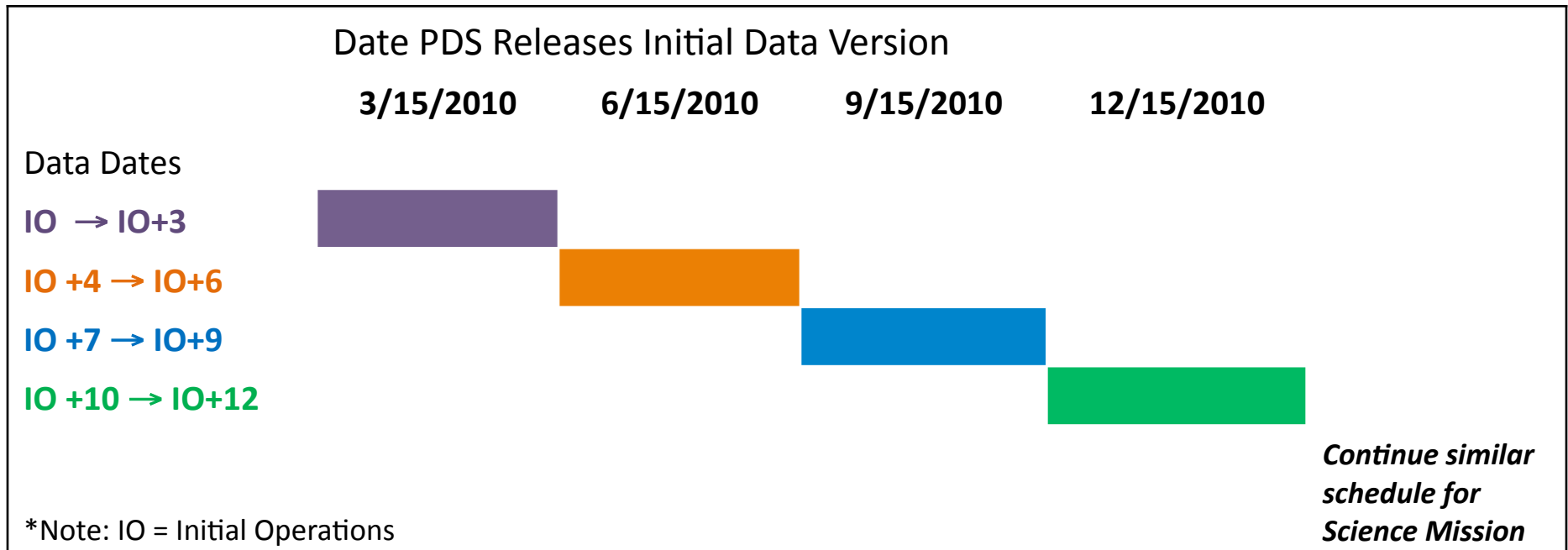

3/15/10 Release = 47.8 Terabytes

6/15/10 Release = 30.2 Terabytes

Polar Regions have long been considered key Lunar landing site

June 19, 1961: Responding to question from Homer Newell, NASA Director Office of Space Sciences, Harold Urey listed high lunar latitudes, as regions of high scientific interest, to determine whether water might exist where temperature extremes were less marked.